

# SAφIC™ Technology – The New Way To Compliance

LFC Semiconductor's proprietary SAφIC™ technology is a revolutionary “Next-Gen” approach to Active EMI / RFI Management (see “An Introduction to Active EMI / RFI Management”).

SAφIC™ - (pronounced “Safic”) stands for “Safe Phase Modulation IC” and incorporates all the benefits of Active EMI / RFI management while overcoming the many limitations of the older 1<sup>st</sup>-Gen methods.

Older Generation Implementations:

The most widely used architecture for 1<sup>st</sup>-Gen Active EMI management is a PLL (Phase Locked Loop) based one. The PLL is used to frequency modulate a periodic signal thereby “spreading” the energy over a wider band and reducing peak emissions. The output frequency is proportional to the ratio of the feed-forward and feedback counter values (M/N) and the modulation is achieved by modifying this ratio either in a pre-determined manner or randomly (dithering).

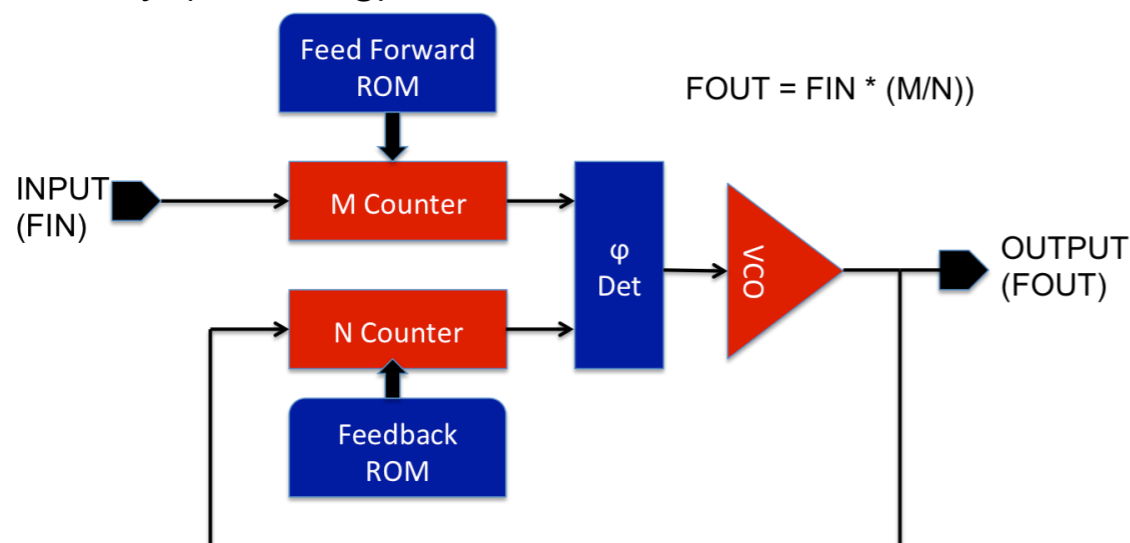

Figure 1 – PLL Based Implementation of Active EMI Management

## Limitations of 1<sup>st</sup> Generation Active EMI Management

1<sup>st</sup> Generation Active EMI Management implementations offer highly effective EMI / RFI suppression in certain applications where there are

- 1) relaxed system timing requirements (low frequency) due to the intrinsic jitter caused by the PLL.
- 2) no requirements for functional compliance / certification for interoperability as in USB or HDMI
- 3) no strict constraints on power consumption (non-mobile applications)

In addition to these limitations most devices based on PLL **architectures exhibit large part-to-part variations** due to the large Analog content in the chip, which can often lead to **system failure in the field**.

These limitations have been the prime reason for the lack of adoption of Active EMI management in many applications like mobile phones, tablets, netbooks to name a few.

# SAΦIC™ Active EMI Management

LFC Semiconductor's new SAΦIC™ technology addresses all these shortcomings and enables its use in numerous applications including those that demand adherence to very strict system timing budgets.

This is achieved by eliminating the requirement of a PLL to effect the modulation (refer Figure 2). The modulation is achieved by the reconstruction of the input signal with a precise but dynamic phase shift over the modulation cycle. The phase shift amount is controlled and has been optimized to provide the maximum EMI suppression with the minimum phase shift. Mathematically, the effective Frequency Modulation is governed by the relation between the instantaneous frequency and phase change given by:

$f_{inst} = \delta(\phi) / \delta(t)$  where  $f_{inst}$  is the instantaneous frequency and  $\delta(\phi) / \delta(t)$  is the rate of change of phase.

By carefully controlling the manner in which the phase of the input signal is modified, the peak energy can be effectively distributed over a wider frequency band. The comparative advantage is tabulated in Table 1.

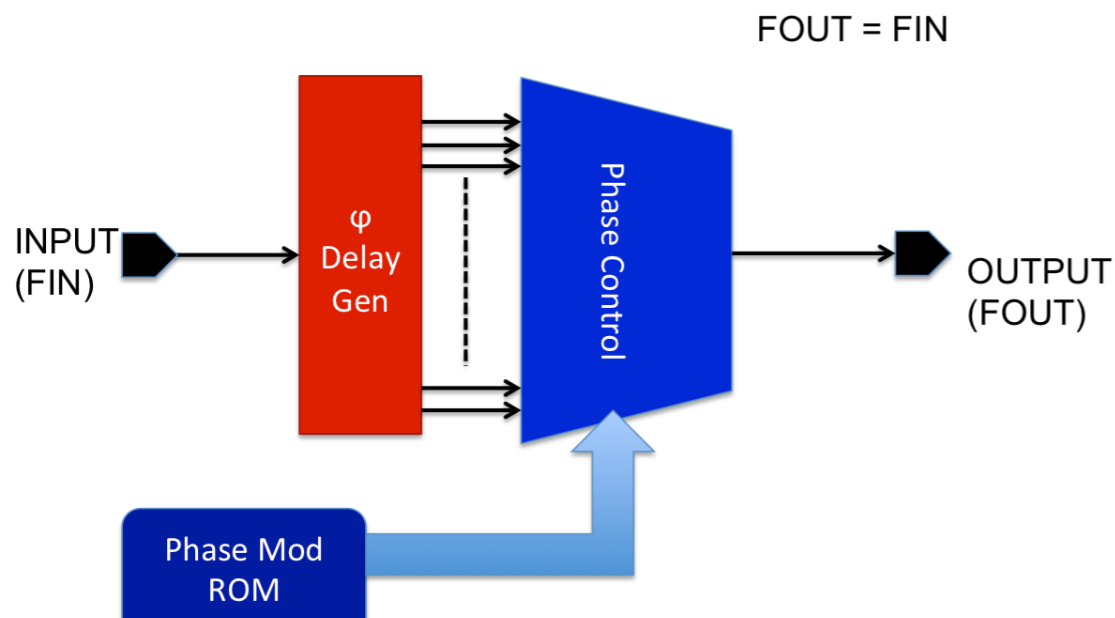

Figure 2 – SAΦIC™ Implementation of Active EMI Management

<ul style="list-style-type: none"> <li>• 1<sup>st</sup> Generation </li> <li>– PLL based</li> <li>– Inherent jitter</li> <li>– Unable to be used in timing sensitive applications (USB, HDMI..)</li> <li>– High Power consumption</li> <li>– High failure rate</li> </ul>	<ul style="list-style-type: none"> <li>• LFC SaΦic™ </li> <li>– No PLL, low power</li> <li>– Maximizes modulation applied to system to allow huge EMI benefits with minimal system timing impact</li> <li>– Allows either full compliance or eye pattern compliance to various standards like USB and HDMI</li> </ul>
---	---

Table 1. - SAΦIC™ vs. 1st Generation Active EMI Management

## LFC Semiconductor's SAΦIC™ LX304

- 1.8V to 3.3V operation
- Proprietary SaΦic™ Technology
- 10 to 50 MHz operation.
- 2mm x 2mm DFN
- Low Jitter
- Ultra Low Power
- Minimal Part to Part Variation
- HDMI and USB Compliance Options

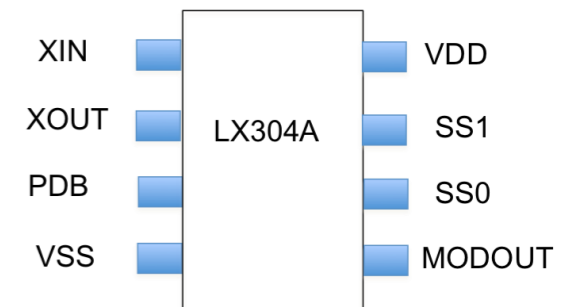

Further Reading:

[An Introduction to Active EMI/RFI Management.](#)

[A Case Study in Compliance with SAΦIC™.](#)